

Device Description



EAE Card Holder is intended to be used for energy saving purposes in hotel guest rooms.

- Monoblock glass design
- Compatible with Mifare 13.56 MHz card (Mifare Ultra Light C model is not supported.)
- Contactless reading for RFID Card information.
- Prevents mechanical wear and card deformation.
- 60x60 mm easy mounting to standard junction boxes.

- Different glass color options
- Configurable RGB illuminated buttons
- Up to 6 independent programmable buttons
 - Switching
 - Dimming
 - Shutter/Blind
 - Value
 - Scene control
 - Status notification

Operation and Display

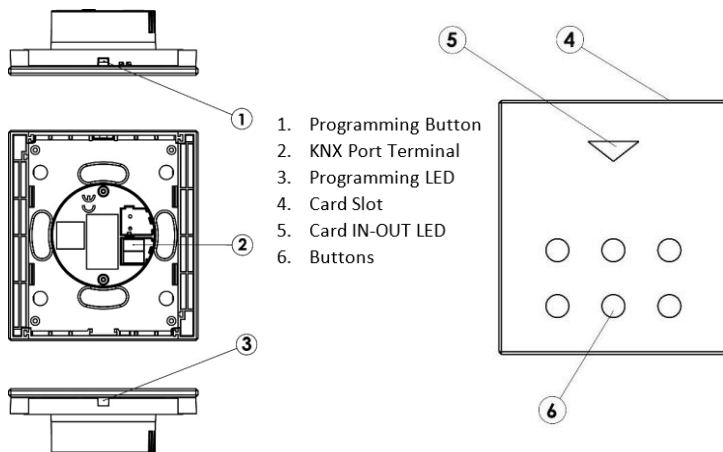

Technical Data

Protection Type	IP20	EN 60 529
Safety Class	II	EN 61 140
Connections	KNX	Bus Connection
Power Supply	Voltage	21V... 30V DC, KNX
	Current drawn from bus	< 25 mA
	LED (red)	KNX phys. Address Prog. LED
	LED (RGB)	Status LED
Operating Elements	Supported Card Type	Mifare 13.56 MHz card - Mifare Classic - Mifare Plus - Mifare Ultralight - Mifare Desfire
	Unsupported Card Type	- Mifare Ultralight C
Operating Temperature	Ambient	-5° C + 45° C
Humidity	Max. Air humidity	85% no moisture
	Front side	90 x 100 mm
	Side – Surface mounted part	12 mm
Dimensions	Side – Flush mounted part	18.8 mm
	Box Material	Surface : Glass Flush Mounted Part : Polycarbonate
Color	Surface : Black or White	
	Flush Mounted Part : Black	
CE	In accordance with the EMC guideline and low voltage directives.	

Installation

Installation of the product is done with metal flange. It is fixed to the junction box by using screws. The switch has magnets and should be positioned the card slot upwards. The device will stick on flange by magnetization. Multiple devices can be combined up to 3.
NOTE: Distance between center of flanges is **71 mm**.

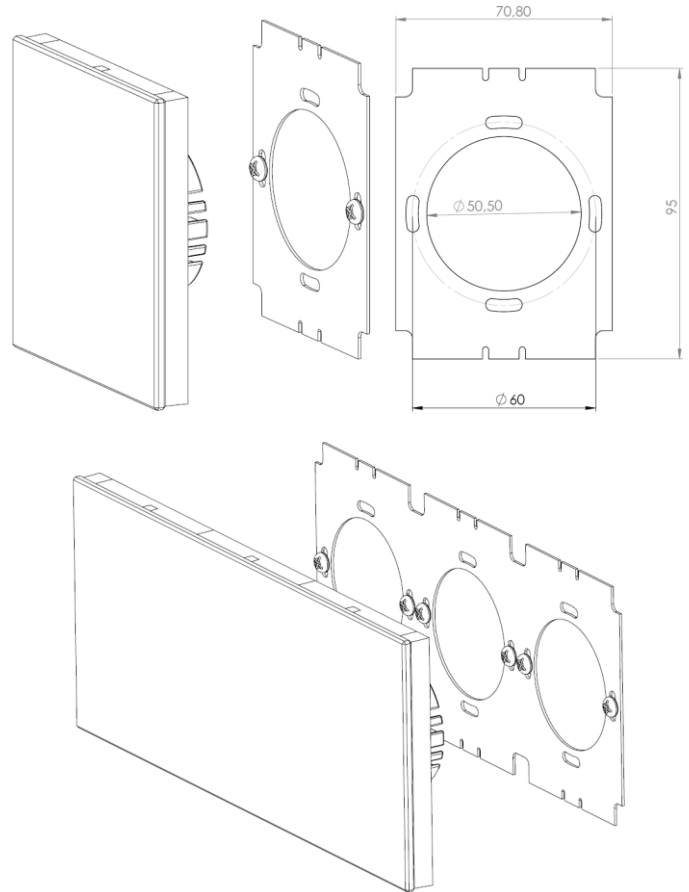

Commissioning

Device default physical address is 15.15.255. Determination of the physical address and setting of parameters are actualized with Engineering Tool Software (ETS5 or higher). “.knxprod” file must be imported to the ETS. (<http://www.eaetechnology.com/>)

i A detailed information about parameter configuration can be found in Product Manual of device.

! Installation and commissioning of device may only be implemented by trained electricians. The relevant standards, directives, regulations and instructions must be observed when planning and implementing the electrical installation.

-Protect the device against moisture, dirt and damage during transport, storage and operation!

-Do not operate the device out of the specified technical data which is stated.

-The device may only be operated in closed enclosures (Distribution boards)

Cleaning

If device becomes dirty, only a dry cloth can be used for cleaning. It is not suitable to use wet cloths, caustics and solvents.