

Connection

1. KNX connection terminal
2. KNX programming button
3. Programming LED

Description of Devices

CD100 KNX Corridor Detectors are ideal for corridors, parking buildings. Detector is available in two models; "Flush Mounted" and "Surface Mounted".

Both models provide the following functions;

- Constant light function
- Corridor function
- Independent presence channel
- HVAC channel
- Master/Slave operation
- Fully automatic-semi automatic operating mode
- Test and calibration mode

Technical Data

Type of protection	IP 20 IP 44 (Surface Mount only)	EN 60 529
Safety class	II	EN 61 140
Power Supply	21V... 30V DC, SELV KNX Bus Current consumption < 10mA	
Application Area	Interior rooms	
Sensor Type	Passive infrared	
Installation	Location Recommended height	Ceiling 2.5m –4,5m
Connections	KNX Bus connection terminal	
Detection	Diameter (at height of 4.5m) 12 x 4 m (radial walk) 20 x 6 m (tangent walk)	
	Angle 180° Light level 100 – 1000 Lux	
Additional channels	Brightness, presence channel, HVAC channel	
Parallel operation	Master/Master, Master/Slave	
Operating elements	LED (red) and programming button to assign physical address	
Dimensions	Height: 62 mm Diameter: 115 mm	
Weight	Flush Mount: 83 gr Surface Mount: 97 gr	
Temperature range	Ambient -5° C + 45° C Storage -25° C + 55° C Transport -25° C + 70° C	
Humidity	Maximum air humidity 95 % no moisture condensation	
Box	Plastic, polycarbonate, white colour	
CE	In accordance with the EMC guideline and low voltage	
Application program	Communication objects 44 Number of addresses(max) 254	

Operation and Display

-Programming Led⁽³⁾

Red led lights up after the programming button is pressed.

Installation

Mounting hole diameter must be **102 mm (4 inches)** in order to install the box of sensor on the ceiling. KNX connector must be connected to the KNX connection terminal. Ensure that coloured cables are connected to terminals accurate.

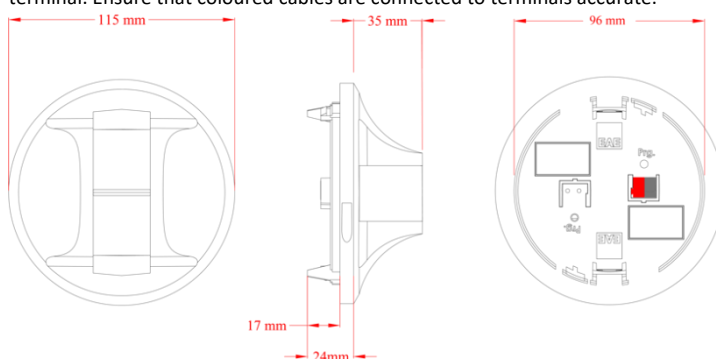

Detection range depends on movement types. These types are divided as follows;

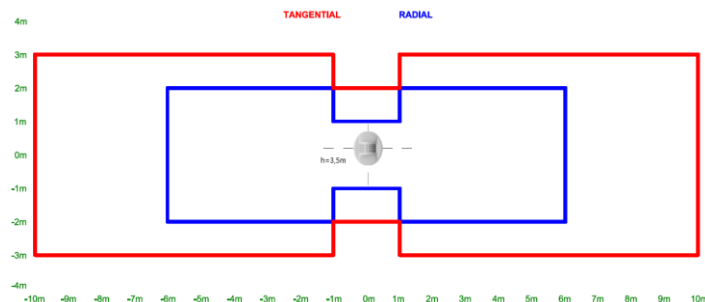

3,5 m Height Detection Area

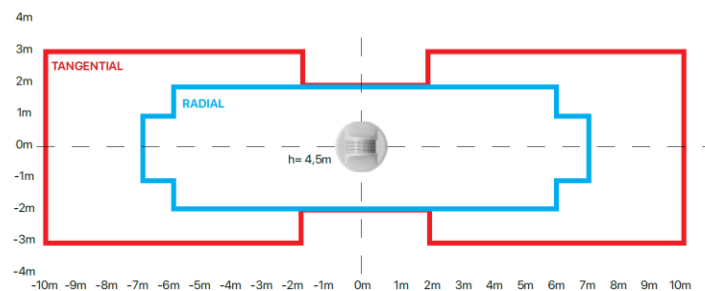

4,5 m Height Detection Area

Commissioning

Determination of the physical address and setting of parameters are actualized with Engineering Tool Software (ETS3/ETS4 or higher). ".knxprod" file must be imported to the ETS. Please check website for latest ".knxprod" file.

www.eaetechnology.com

i A detailed information about parameter configuration can be found in Product Manual of device.

! Installation and commissioning of device may only be implemented by trained electricians. The relevant standards, directives, regulations and instructions must be observed when planning and implementing the electrical installation.

- When connecting the device make sure that the device is isolated!
- Protect the device against moisture, dirt and damage during transport, storage and operation!
- Do not operate the device out of the specified technical data which is stated.
- The device may only be operated in closed enclosures (Distribution boards etc.)

Cleaning

If device becomes dirty, only a dry cloth can be used for cleaning. It is not suitable to use wet cloths, caustics and solvents.